

JLBIDO913

Built in double oven

Instruction manual

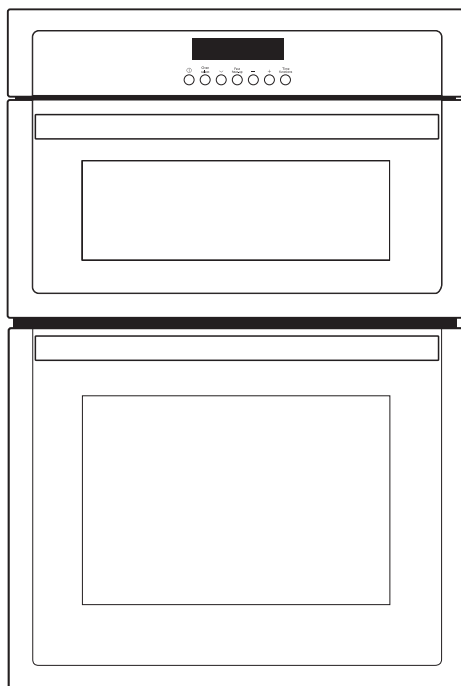

John Lewis

Safety information

It is most important that this instruction book should be retained with the appliance for future reference. Should the appliance be sold or transferred to another owner, or should you move house and leave the appliance, always ensure that the book is supplied with the appliance in order that the new owner can get to know the functioning of the appliance and the relevant warnings.

These warnings have been provided in the interest of safety. You **MUST** read them carefully before installing or using the appliance. If you are unsure of the meanings of these warnings contact the John Lewis branch from which you purchased the appliance.

These warnings are provided in the interests of your safety. Ensure that you understand them all before installing or using the appliance.

Your safety is of paramount importance. If you are unsure about any of the meanings of these warnings please contact customer care.

Installation

- The appliance must be installed according to the instructions supplied.
- The installation work must be undertaken by a qualified electrician or competent person.
- The appliance should be serviced by an authorised Service Engineer and only genuine approved spare parts should be used.
- The appliance must be installed in an adequately ventilated room.
- It is imperative that the appliance is left in the base to protect both the appliance and the floor.
- This appliance is heavy and care must be taken when moving it. Always wear safety gloves.
- Do not attempt to lift or move this appliance by the handles.

- All packaging, both inside and outside the appliance must be removed before the appliance is used.
- It is dangerous to alter the specifications or modify the appliance in any way.

Child safety

- Do not allow children to play with any part of the packaging.
- Do not allow children to sit or climb on the drop down doors.
- This appliance is not intended for use by children and other persons whose physical, sensory or mental capabilities or lack of experience and knowledge prevents them from using the appliance safely without supervision or instruction by a responsible person to ensure that they can use the appliance safely.
- Children should be supervised to ensure that they do not play with the appliance.



Caution! Accessible parts may become hot during use, to avoid burns young children should be kept away.

During use



Warning! Never leave the appliance unattended when the oven door is open.

- This appliance is not intended to be operated by means of an external timer or separate remote control system.
- This appliance has been designed for domestic use to cook edible foodstuffs only and must not be used for any other purposes.
- Take great care when heating fats and oils as they will ignite if they become too hot.
- Never place plastic or any other material that may melt in or on the oven.
- Always support the grill pan when it is in the withdrawn or partially withdrawn position.
- Always use oven gloves to remove and place food in the oven.
- During use the appliance becomes hot. Care should be taken to avoid touching the heating elements inside the oven.
- Ensure that all vents are not obstructed to ensure ventilation of the oven cavity.
- Never line any part of the appliance with foil.
- Always stand back from the appliance when opening the oven door to allow any build up of steam or heat to release.
- Stand clear when opening the drop down doors. Support the doors using the handles until fully open.

- Do not place sealed cans or aerosols inside the oven. They may explode if they are heated.
- Ensure that all control knobs are in the OFF position when not in use.
- Do not stand on the appliance or on the open oven doors.
- Do not hang towels, dishcloths or clothes from the appliance or its handles.
- Do not use this appliance if it is in contact with water. Never operate it with wet hands.

Cleaning and maintenance



Warning! For hygiene and safety reasons this appliance should be kept clean at all times. A build-up of fat or other foodstuff could result in a fire especially in the grill pan.

- Do not leave cookware containing foodstuffs, e.g. fat or oil in the appliance in case it is inadvertently switched on.
- Always allow the appliance to cool before switching off at the wall prior to carrying out any cleaning/maintenance work.
- Only clean this appliance in accordance with the instructions given in this book.
- Never use steam or high pressure steam cleaners to clean the appliance.

Contents

For the User

Safety information 2

Product description 5

General overview 5

Control Panel Overview 5

Oven accessories 6

Before first use 6

Preparing to use your appliance 6

Cookware 7

Setting the Time 7

Initial Cleaning 7

Operation 8

The top oven 8

Double oven operation 8

Selecting an oven 8

Child safety device 14

Tips, tables and advice 15

Roasting 16

Top Oven - Full Width Grilling 18

Top Oven - Conventional Cooking 19

Main Oven - Fan Grilling 21

Main Oven - Full Width Grilling 22

Main Oven - Fan Cooking 23

Main Oven - Fan Cooking 24

Main Oven - Conventional Cooking 24

Care and cleaning 25

Oven door glass 28

Cleaning the outside of the appliance 31

Cleaning inside the grill and oven compartments 31

31

What to do if... 32

For the Installer

Installation 34

Electrical Installation 36

Disposal 37

Repairs - after sales service 38

www.electrolux.com 38

Guide to use the instruction manual

The following symbols will be found in the text to guide you throughout the instructions:



Safety instructions



Hints and tips



Environmental information

Product description

General overview

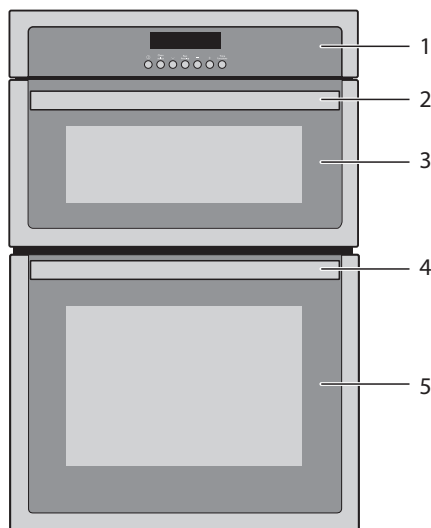

- 1** Control panel
- 2** Top oven handle
- 3** Top oven
- 4** Main oven handle
- 5** Main oven

Control Panel Overview

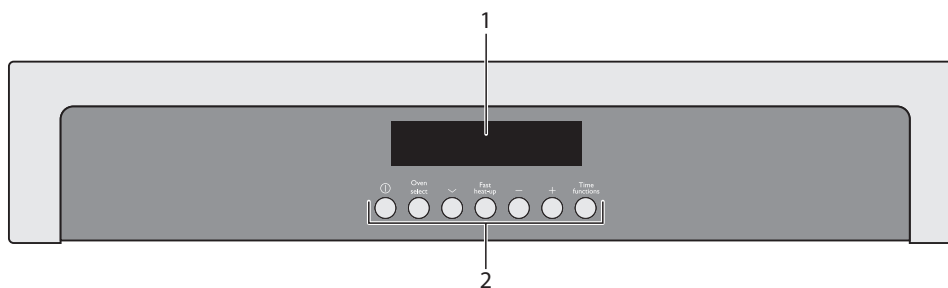

- 1** Display
- 2** Function keys

Oven accessories

3 oven shelves

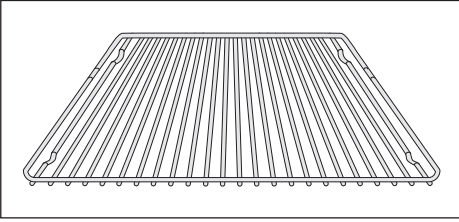

Oven grill shelf

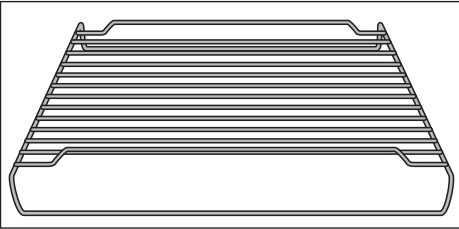

Anti stick meat/Drip pan

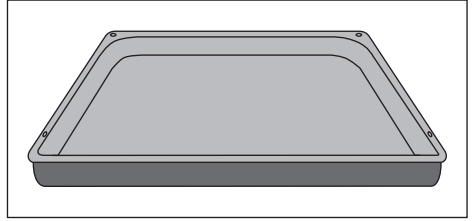

Before first use

Rating plate

This is situated on the front frame of the appliance and can be seen upon opening the door. Alternatively the rating plate may also be found on the back or top of some models (where applicable).

The appliance must be protected by a suitably rated fuse or circuit breaker.

The rating of the appliance is given on the rating plate.



Warning! Do not remove the rating plate from the appliance as this may invalidate the guarantee.

Preparing to use your appliance

Wipe over the base of the oven(s) with a soft cloth using hot soapy water. Wash the furniture before use.

We suggest that you run the oven(s) and grill for 10–15 minutes at maximum temperature, to burn off any residue from their surfaces.

Accessible parts may become hotter than in normal use. Children should be kept away. During this period an odor may be emitted, it is therefore advisable to open a window for ventilation.

Important! There is a hot surface label on the oven door. Please remove the label from the door before first use of the appliance.

The cooling fan

The cooling fan comes on immediately the top oven or grill is switched on. It may run on after the ovens are switched off until the appliance has cooled. During the cooling down period the cooling fan may switch on and off.



Warning! Always allow the cooling fan to cool the appliance down before switching off the electrical supply to carry out cleaning or maintenance.

Control panel indicator neon(s)

The indicator neon will operate when the oven(s) is switched on. The indicator neon will glow. It may turn on and off during use to show that the setting is being maintained. If the neon does not operate as the instructions indicate the controls have been incorrectly set. Return all controls to zero and reset following the instructions for the required setting.

Condensation and steam

When food is heated it produces steam similar to a boiling kettle. The vents allow some of this steam to escape. However, always stand back from the appliance when opening the door(s) to allow any build up of steam or heat to release.

If the steam comes into contact with a cool surface on the outside of the appliance, e.g. a trim, it will condense and produce water droplets. This is quite normal and is not caused by a fault on the appliance.

To prevent discoloration, regularly wipe away condensation and foodstuff from surfaces. For your safety wall coverings at the rear of the appliance should be securely fixed to the wall.

Cookware

Baking trays, dishes etc., should not be placed directly against the grid covering the fan at the back of the oven.

Do not use baking trays larger than 30cm x 35cm (12" x 14") as they will restrict the circulation of heat and may affect performance.

Setting the Time



The oven only operates when the time has been set.

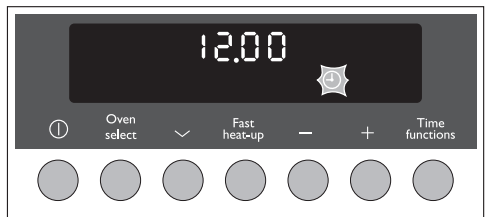

1. When the appliance is connected to the electrical supply or when there has been a power cut, Time ⌚ flashes automatically.
2. Using the + or - button, set the current time.
3. After approx. 5 seconds, the clock stops flashing and the clock displays the time of day set.
The appliance is now ready to use.

Initial Cleaning



Before using the oven for the first time, you must clean it.



Warning! Do not use sharp, abrasive cleaning agents! These could damage the surface.

i For metal fronts, use normal commercially available cleaning agents.

1. Open door.
The oven light is activated.
2. Remove all accessories and the slide-in grids and clean with warm water and washing-up liquid.

3. Wipe the floor of the oven clean with warm washing-up solution and dry.
4. Wipe the front of the appliance with a damp cloth.
5. Insert the oven shelf runners supplied, as described in the chapter "Cleaning and Care".

Operation

The top oven

The top oven is the smaller of the two ovens. It is heated by elements in the top and bottom of the oven. It is designed for cooking smaller quantities of food. It gives especially good results if used to cook fruitcakes, sweet and savoury flans or quiche.

The top oven is ideal for use as a warming compartment. It can be used to warm dishes and keep food hot. Use the lowest setting on the top oven temperature control.

Warning! Do not place cookware and cooking pots with rough bases e.g. cast iron on the oven door as damage to the glass may occur.

Important! Always grill with the door closed.

Double oven operation

The appliance has two ovens. Press the relevant button on the control panel to switch between top and bottom oven mode. Some of the heating and electronic functions may not be available in the top oven. For list of heating functions see the relevant table in the Operation chapter.

Selecting an oven

1. Switch on the appliance using the On/Off  button.
2. Press the "OVEN SELECT" button repeatedly until the desired oven appears (Top / Main)

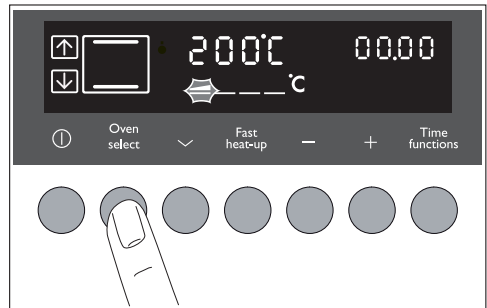

Selecting an oven function

Press the  button repeatedly until the desired oven function appears. A suggested temperature appears in the temperature display. If the suggested temperature is not changed within approx. 5 seconds, the oven starts to heat up.

i The oven function can be changed while the oven is working.

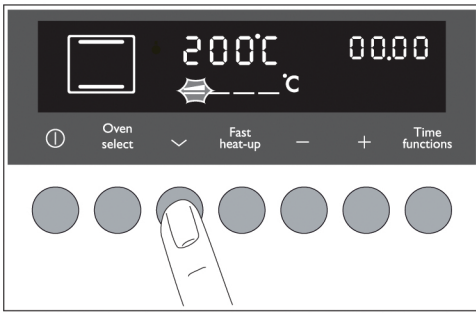

Selecting an clock function

Press the "TIME FUNCTIONS" button repeatedly until the desired clock function is flashing.

For further information check section "Clock Function"

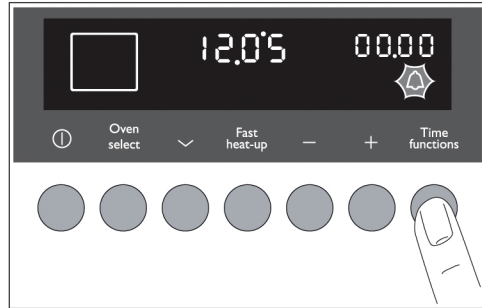

Changing the oven temperature

Press the + or - button, to raise or lower the temperature.

The setting changes in steps of 5°C.

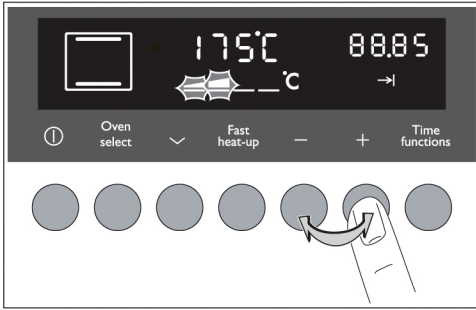

Switching off the oven function

To switch off the oven, press the ∨ button repeatedly until no oven function is displayed any more.

i If there has been no oven function and no clock function working for about 2 minutes, the appliance switches itself off automatically.

But the bar display remains lit.

To switch the light bars off, switch the appliance on using the On/Off Ⓛ button and switch it off again.

Switching the oven off

Switch off the appliance using the On/ Off Ⓛ button.

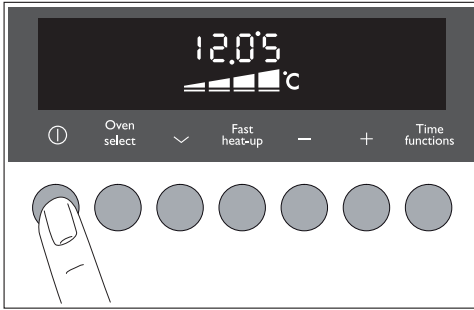

Heat indicator

Warming up indicator

When the oven function has been switched on the bars that slowly light up one after the other indicate how far the oven has heated up.

Residual heat indicator







When the oven has been switched off, the bars that are still lit indicate the residual heat remaining in the oven.

Cooling fan





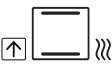

















The fan switches on automatically in order to keep the appliance's surfaces cool. When the oven is switched off, the fan continues to run to cool the appliance down, then switches itself off automatically.

The oven has the following functions

Top oven

Oven function		Application
	Light	Using this function you can light up the oven interior, e.g. for cleaning.
	Conventional Cooking	This form of cooking gives you the opportunity to cook without the fan in operation. It is particularly suitable for dishes, which require extra base browning such as pies, quiches and flans. Gratin's, lasagne and hot pots which require extra top browning also cook well in the conventional oven. For best results cook on one level.
	Full width grilling	For grilling flat foodstuffs in large quantities and for toasting.
	Half width grilling	For grilling flat foodstuffs in small quantities.
	Keep Warm	Suitable for heating and keeping the food warm.
	Bottom heat	For baking cakes with crispy or crusty bases.

Main oven

Oven function	Application
 	<p>Fan cooking</p> <p>The fan function is particularly suitable for cooking larger quantities of food. Set the oven temperatures 20-40 °C lower than when using Conventional.</p>
 	<p>Conventional Cooking</p> <p>This form of cooking gives you the opportunity to cook without the fan in operation. It is particularly suitable for dishes, which require extra base browning such as pies, quiches and flans. Gratin's, lasagne and hot pots which require extra top browning also cook well in the conventional oven. For best results cook on one level.</p>
 	<p>Pizza setting</p> <p>For baking on one oven level dishes that require more intensive browning and a crispy base. Set the oven temperatures 20-40 °C lower than when using Conventional.</p>
 	<p>Slow Cook</p> <p>For preparing especially tender, succulent roast.</p>
 	<p>Fan Grilling</p> <p>For roasting larger joints of meat or poultry on one level. The function is also suitable for gratinating and browning.</p>
 	<p>Full width grilling</p> <p>For grilling flat foodstuffs in large quantities and for toasting.</p>
 	<p>Half width grilling</p> <p>For grilling flat foodstuffs in small quantities.</p>
 	<p>Fan defrosting</p> <p>For defrosting e. g. flans and gateaux, butter, bread, fruit or other frozen foods.</p>
 	<p>Light</p> <p>Using this function you can light up the oven interior, e.g. for cleaning.</p>
 	<p>Keep Warm</p> <p>Suitable for heating and keeping the food warm.</p>
 	<p>Bottom heat</p> <p>For baking cakes with crispy or crusty bases.</p>



Warning!

Always grill with oven door closed

Clock Functions

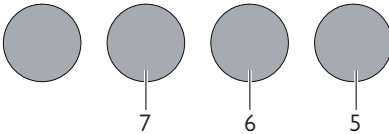
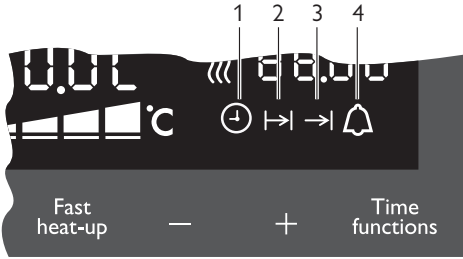

- 1 Time
- 2 Cook time
- 3 End time
- 4 Countdown
- 5 TIME FUNCTIONS button
- 6 Selection button (Plus)
- 7 Selection button (Minus)

Countdown

To set a countdown. A signal sounds after the time has elapsed.

This function does not affect the functioning of the oven.

Cook time

To set how long the oven is to be in use.

End time

To set when the oven is to switch off again.

Time

To set, change or check the time (See also section "Before Using for the First Time").

How to use the clock functions

- After a clock function has been selected, the corresponding function flashes for about 5 seconds. During this period, the

desired times can be set or modified using the $+$ or $-$ button.



- When the desired time has been set, the function continues to flash for approx. 5 seconds. After that the function is then lit. The set time begins to run.
- With Countdown the oven must also be switched on in order to set the clock function.
- By pressing $+$ and $-$ at the same time, the time set can be reset.



Checking the time set or remaining
Press the Selection button repeatedly, until the appropriate clock function flashes and the time set or remaining is displayed.



Using residual heat with the Cook time and End time clock functions

When the Cook time  and End time  clock functions are used, the oven switches the heating elements off, when 90% of the time set or calculated has elapsed. The residual heat present is used to continue the cooking process until the time set has elapsed (3 to 20 mins.).

Countdown

1. Press the "TIME FUNCTIONS" button repeatedly until Countdown  flashes.
2. Set the desired Countdown using the $+$ or $-$ button.

After about 5 seconds the display shows the time remaining. Countdown  lights up. When 90% of the time set has elapsed, an audible signal sounds.

When the time has elapsed, an audible signal sounds for 1 minute. "00.00" and Countdown 🔔 flash.

To stop the flashing and the audible signal: Press any button.

Cook time |→|

1. Select the oven function and temperature.
2. Press the "TIME FUNCTIONS" button repeatedly until Cook time |→| flashes.
3. Set the desired cooking time using the + or - button (max. 09.59 hours).

Cook time |→| lights up.

When the time has elapsed, "00.00" and Cook time |→| flash.

An audible signal sounds for 2 minutes.

The oven switches itself off.

To stop the flashing and the audible signal: Press any button.

End time →|

1. Select the oven function and temperature.
2. Press the "TIME FUNCTIONS" button repeatedly until End time →| flashes.
3. Using the + or - button set the desired switch-off time.

End time →| lights up and the cook time calculated is displayed.

When the time has elapsed, "00.00" and End time →| flash.

An audible signal sounds for 2 minutes.

The oven switches itself off.

To stop the flashing and the audible signal: Press any button.

Cook time |→| and End time →| combined

 Cook time |→| and End time →| can be used at the same time, if the oven is to be automatically switched on and off at a later time.

1. Select the oven function and temperature.
2. Using the Cook time |→| function, set the time that the dish needs to cook, for example: 1 hour.
3. Using the End time →| function, set the time at which the dish should be ready, for example: 14:05.

Cook time |→| and End time →| light up.

The oven switches on automatically at the time calculated,

for example: at 13:05.

When the Cook time set has elapsed, an audible signal sounds for 2 minutes and the oven switches itself off, for example: at 14:05.

Changing the Time ⌚

 The time can only be modified, if the child safety device is deactivated, neither of the clock functions Cook time |→| or End time →| nor any oven functions are set.

1. Press the "TIME FUNCTIONS" button repeatedly until Time ⌚ flashes.
2. Using the + or - button, set the current time.

After approx. 5 seconds, the clock stops flashing and the clock displays the time of day set.

The appliance is now ready to use.

Keep Warm

The Keep Warm function keeps your prepared dish warm for 30 minutes, after the baking or roasting process is completed. This is helpful, for example, if your guests are late.

Pre-condition for Keep Warm:
Set temperature is above 80°C

Switching on Keep Warm

1. Set clock functions Cook time $\left| \rightarrow \right|$ and/or End time $\rightarrow \left| \right|$.
2. Press the "TIME FUNCTIONS" button repeatedly until the symbol Keep Warm \llcorner appears in the display.
3. Press the \oplus button. "00:30:" appears in the display.
4. As soon as the oven function is completed, a signal sounds and Keep Warm starts.

The oven function set runs at 80°C for 30 minutes.

As soon as the 30 minutes with Keep Warm are over, the oven switches itself off.

 Irrespective of an oven function being set, Keep Warm remains active. You can change between the oven functions.

Child safety device

As soon as the child safety device is set, the appliance can no longer be switched on.

Activating the child safety device

1. If necessary, **switch on** the appliance using the On/Off ⓪ button. **No oven function must be selected.**
2. Press and hold the "TIME FUNCTIONS" and — buttons at the same time, until "SAFE" appears in the display.

The child safety device is now set.

Cancelling the child safety device

1. If necessary, switch on the appliance using the On/Off ⓪ button.
2. Press and hold the "TIME FUNCTIONS" and — buttons at the same time, until "SAFE" disappears from the display.

The child safety device is now cancelled and the appliance is again ready for use.

Button lock

To ensure that oven functions set are not accidentally altered.

Activating the button lock

1. If necessary, **switch on** the appliance using the On/Off ⓪ .
2. Select the oven function.
3. Press and hold the "TIME FUNCTIONS" and — buttons at the same time, until "LOC" appears in the display.

The button lock is now engaged.

Cancelling the button lock

Press and hold the "TIME FUNCTIONS" and — buttons at the same time, until "LOC" disappears from the display.

The button lock is automatically lifted when the oven function is switched off.

Heat and Hold

The Heat and Hold function keeps your prepared dish warm for 30 minutes, after the baking or roasting process is completed. This is helpful, for example, if your guests are late.

Pre-condition for Heat and Hold:
Set temperature is above 80°C

Switching on Heat and Hold

1. Set clock functions Cook time $\left| \rightarrow \right|$ and/or End time $\rightarrow \left| \right|$.

2. Press the "TIME FUNCTIONS" button repeatedly until the symbol Keep warm \llcorner appears in the display.
3. Press the \oplus button. "00:30:" appears in the display.
4. As soon as the oven function is completed, a signal sounds and Heat +Hold starts.

The oven function set runs at 80°C for 30 minutes.

As soon as the 30 minutes with Heat and Hold are over, the oven switches itself off.

i Irrespective of an oven function being set, Heat and Hold remains active. You can change between the oven functions.

The oven switches itself off when the oven temperature is:

- 30 - 120°C after 12.5 hours
- 120 - 200°C after 8.5 hours
- 200 - 250°C after 5.5 hours
- 250 – max °C after 3 hours

Using the appliance after an automatic cut-out

i The automatic cut-out is cancelled, if the clock function Cook time $| \rightarrow | /$ End time $\rightarrow |$ or the oven function Slow cook \square is set.

Oven Automatic cut-out

i If the oven not switched off after a certain time, or if the temperature is not modified, it switches off automatically.
The last temperature set appears in the temperature display.

Tips, tables and advice

Baking

Oven levels

- Baking with Conventional Cooking is only possible on one level.
- When baking with Fan Cooking one to two baking trays can be put into the bottom oven at the same time:

1 tray, e.g. oven level 3

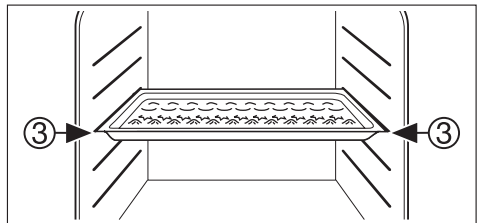

1 cake in cake tin, e.g. oven level 1

1

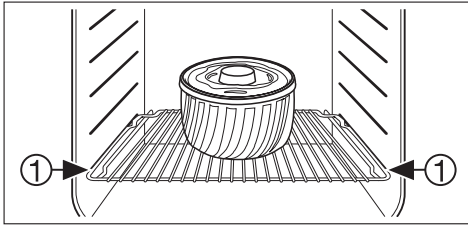

2 tray, e.g. oven levels 1 and 3

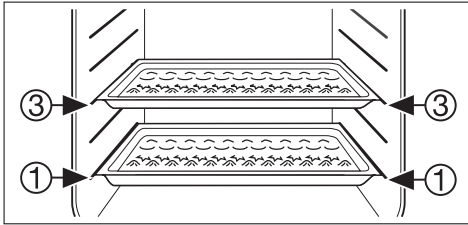

Baking tins

- Baking tins made from dark-coloured metal with Teflon coating are suitable for baking using Conventional Cooking.
- For baking using the Fan Cooking function, baking tins made of shiny light-coloured metal are suitable.

General instructions

- Insert the tray with the bevel at the front.
- When baking using Conventional Cooking and Fan Cooking, you can also place two baking trays next to one another on one level. This does not significantly affect the baking time.



When frozen items are placed on baking trays, they can buckle during cooking. This happens due to the large difference in temperature between the frozen item and the oven. After cooling, the buckling in the trays disappears.

How to use the Baking Tables

- The tables give the required temperature settings, cooking times and oven levels for a selection of typical dishes.
- Temperatures and baking times are for guidance only, as these will depend on the consistency of pastry, dough or mixture, the amount and the type of baking tin.
- We recommend setting the oven to a lower temperature for the first time and only setting a higher temperature when required, e.g. if you require more browning or if the baking is taking too long.
- If you cannot find the settings for a certain recipe, look for similar items.
- The baking time can be 10-15 minutes longer when baking cakes on trays or in tins on multiple levels.
- Recipes with moist ingredients such as pizzas or fruit flans are to be baked on one level.
- Cakes and pastries at different heights may brown at an uneven rate at first. You should not change the temperature setting if this occurs. Different rates of browning even out as baking progresses.
- Baking and roasting times could differ from those of your previous oven. For this reason you should adjust the settings you usually use (temperature, cooking times, etc.) and oven levels to the recommendations provided in the following tables.

Roasting

Ovenware for roasting

- Any heat-resistant ovenware is suitable to use for roasting. (Please follow the manufacturer's instructions.)
- You can place large roasts **directly in the roasting tray or on the shelf with the roasting tray underneath.**

- We recommend roasting leaner cuts **in a roasting pan with a lid**. The meat will be more succulent.
- All types of meat which are supposed to be browned or form a crust or crackling can be roasted in a **roasting pan without a lid**.

 The information given in the following tables is for guidance only.

- We recommend meat and fish **weighing 1 kg or more** for roasting in the oven.
 - To prevent escaping meat juices or fat from burning on to the pan, we recommend placing some liquid in the roasting cookware.
 - If required, turn the roast after 1/2 - 2/3 of the cooking time.
 - Use the cooking juices to baste large roasts and poultry several times during the cooking time. This will give better roasting results.
- Accompaniments such as tomatoes and mushrooms may be placed underneath the grid when grilling meats.
 - When toasting bread, use the shelf in the top position with the grid in the 'high' position.
 - Preheat the grill on a full setting for a few minutes before sealing steaks or toasting. Adjust the heat setting and the shelf as necessary during cooking.
 - The food should be turned over during cooking as required.
 - When using the centre section grill, ensure food is placed centrally on the grilling grid directly beneath the grill element.

 **Warning!**

Always grill with oven door closed

Hints and tips when using the top oven

- Arrange the shelves in the required positions before switching the oven ON. Shelf positions are counted from the bottom upwards.
- There should always be at least 2.5cm (1") between the top of the food and the element. This gives best cooking results and allows room for rise in yeast mixtures, Yorkshire puddings etc. When cooking cakes, pastry, scones bread etc., place the tins or baking trays centrally on the shelf.
- Ensure that food is placed centrally on the shelf and there is sufficient room around the baking tray/dish to allow for maximum circulation.
- Stand dishes on a suitably sized baking tray on the shelf to prevent spillage onto the oven base and to help reduce cleaning.

Hints and tips when using the grill

- Most foods should be placed on the grid in the grill pan to allow maximum circulation of air and to lift the food out of the fats and juices.
- Adjust the grid and grill pan runner position to allow for different thicknesses of food.
- Position the food close to the element for faster cooking and further away for gentler cooking.
- Food should be thoroughly dried before grilling to minimise splashing. Brush lean meats and fish lightly with a little oil or melted butter to keep them moist during cooking.

- The material and finish of the baking tray and dishes used affect base browning. Enamelware, dark, heavy or non-stick utensils increase base browning. Shiny aluminium or polished steel trays reflect the heat away and give less base browning.
- Because of the smaller cooking space and lower temperatures, shorter cooking times are sometimes required. Be guided by the recommendations given in the cooking chart.
- For economy leave the door open for the shortest possible time, particularly when placing food into a pre-heated oven.

Hints and tips when using fan cooking

- Arrange the shelves in the required positions before switching the oven on. Shelf positions are counted from the bottom upwards.
- When cooking more than one dish in the fan oven, place dishes centrally on different shelves rather than placing several dishes on one shelf, this will allow the heat to circulate freely for the best cooking results.
- When batch baking one type of food, e.g. Victoria sandwich cakes, those of similar size will be cooked in the same time.
- It is recommended that when baking larger quantities the shelf positions should be evenly spaced to suit the load being cooked. A slight increase in cooking time may be necessary.
- Do not place baking trays directly on the oven base as it interferes with the oven air circulation and can lead to base burning; use the lower shelf position.

Hints and tips when defrosting

- Place the frozen food in a single layer where possible and turn it over half way through the defrosting process.
- The actual speed of defrosting is influenced by room temperature. On warm days defrosting will be faster than on cooler days.
- It is preferable to thaw fish, meat and poultry slowly in the fridge. However, this process can be accelerated by using the defrost function. Small or thin fish fillets, frozen peeled prawns, cubed or minced meat, liver, thin chops, steaks etc., can be thawed in 1 – 2 hours.
- A 1kg/2¼lb oven ready chicken will be thawed in approximately 5 hours. Remove the giblets as soon as possible during the thawing process.
- Joints of meat up to 2kg/4½lb in weight can be thawed using the defrost function.
- All joints of meat and poultry must be thawed thoroughly before cooking.
- Always cook thoroughly immediately after thawing.
- Do not leave food at room temperature once it is defrosted. Cook raw food immediately or store cooked food in the fridge, once it has cooled.

Top Oven - Full Width Grilling



Adjust shelf position and grill pan grid to suit different thicknesses of food

Food	Grill Time (mins in total)
Bacon Rashers	5 - 6
Beefburgers	10 - 20
Chicken Joints	20 - 40
Chops	
- Lamb	15 - 25
- Pork	20 - 25
Fish - Whole Trout/ Makarel	10 - 12
Fillets - Plaice/Cod	4 - 6
Kebabs	12 - 18
Kidneys - Lamb/Pig	6 - 10
Sausages	20 - 30
Steaks	
- Rare	4 - 6
- Medium	6 - 8
- Well Done	12 - 15
Toasted Sandwiches	3 - 4

Top Oven - Conventional Cooking



Shelf Positions are not critical but ensure that oven shelves are evenly spaced when more than one is used (e.g. shelf positions 1 and 3)

Food	Temperature [°C]	Approx Cook Time (mins)	Shelf Position
Biscuits	170 - 190	10 - 20	3
Bread	200 - 220	30 - 35	2
Bread rolls/buns	170 - 180	10 - 15	1
Cakes:			
- Small & Queen	160 - 170	18 - 25	3
- Sponges	160 - 175	20 - 30	3

Food	Temperature [°C]	Approx Cook Time (mins)	Shelf Position
- Victoria Sandwich	160 - 170	18 - 25	3
- Madeira	140 - 150	75 - 90	2
- Rich Fruit	140 - 150	120 - 150	2
- Gingerbread	140 - 150	75 - 90	2
- Meringues	90 - 100	150 - 180	2
- Flapjack	160 - 170	25 - 30	2
- Shortbread	130 - 150	45 - 65	2
Casseroles:			
- Beef/Lamb	160 - 170	150 - 180	2
- Chicken	160 - 180	75 - 90	2
Convenience Foods	Follow manufacturer's instructions.		
Fish	170 - 190	20 - 30	2
Fish Pie (Potato Topped)	190 - 200	20 - 30	2
Fruit Pies, Crumbles	190 - 200	30 - 50	2
Milk Puddings	150 - 170	90 - 120	2
Pasta Lasagne etc.	170 - 180	40 - 50	2
Pastry:			
- Choux	180 - 190	30 - 40	2
- Eclairs, Profiteroles	180 - 190	30 - 40	2
- Flaky/Puff Pies	210 - 220	30 - 40	2
Shortcrust:			
- Mince Pies	190 - 210	15 - 20	2
- Meat Pies	190 - 210	25 - 35	2
- Quiche, Tarts, Flans	180 - 200	25 - 50	2
Scones	220 - 230	8 - 12	3
Shepard's Pie	180 - 190	30 - 40	2
Soufflés	190 - 200	20 - 30	2
Vegetables:			
- Baked Jacket Potatoes	180 - 190	60 - 90	2
- Roast Potatoes	180 - 190	60 - 90	2
Yorkshire Pudding:			

Food	Temperature [°C]	Approx Cook Time (mins)	Shelf Position
- Large	200 - 210	25 - 40	2
- Individual	210 - 220	15 - 25	2
Roasting Meat, Poultry	See roasting chart.		

Main Oven - Fan Grilling

Beef

Type of meat	Quantity	Heating Function	Level	Temperature (°C)	Time (h:min)
Pot roast	1 - 1.5 kg	Conventional Cooking	3	200 - 250	2:00 - 2:30
Topside beef or fillet					per cm of thickness
- rare ¹⁾	per cm of thickness	Turbo Grill	3	190 - 200	0:05 - 0:06
- medium	per cm of thickness	Turbo Grill	3	180 - 190	0:06 - 0:08
- well done	per cm of thickness	Turbo Grill	3	170 - 180	0:08 - 0:10

1) Pre-heat oven

Pork

Type of meat	Quantity	Heating Function	Level	Temperature (°C)	Time (h:min)
Shoulder, neck, ham	1 - 1.5 kg	Turbo Grill	3	160 - 180	1:30 - 2:00
Pork chop	1 - 1.5 kg	Turbo Grill	3	160 - 180	1:00 - 1:30
Meatloaf	750 g - 1 kg	Turbo Grill	3	160 - 170	0:45 - 1:00
Knuckle of pork (pre-cooked)	750 g - 1 kg	Turbo Grill	3	150 - 170	1:30 - 2:00

Veal

Type of meat	Quantity	Heating Function	Level	Temperature (°C)	Time (h:min)
Roast veal	1 kg	Turbo Grill	3	160 - 180	1:30 - 2:00
Knuckle of veal	1.5 - 2 kg	Turbo Grill	3	160 - 180	2:00 - 2:30

Lamb

Type of meat	Quantity	Heating Function	Level	Temperature (°C)	Time (h:min)
Roast lamb, leg of lamb	1 - 1.5 kg	Turbo Grill	3	150 - 170	1:15 - 2:00
Saddle of lamb	1 - 1.5 kg	Turbo Grill	3	160 - 180	1:00 - 1:30

Game

Type of meat	Quantity	Heating Function	Level	Temperature (°C)	Time (h:min)
Saddle of hare, leg of hare ¹⁾	Up to 1 kg	Turbo Grill	3	220 - 250	0:25 - 0:40
Loin of Game	1.5-2 kg	Turbo Grill	1	210 - 220	1:15 - 1:45
Leg of Game	1.5 - 2 kg	Turbo Grill	1	200 - 210	1:30 - 2:15

1) pre-heat oven

Poultry)

Type of meat	Quantity	Heating Function	Level	Temperature (°C)	Time (h:min)
Poultry pieces	per 200-250g	Turbo Grill	3	200 - 220	0:35 - 0:50
Half chicken	per 400-500g	Turbo Grill	3	190 - 210	0:35 - 0:50
Poultry	1 - 1.5 kg	Turbo Grill	1	190 - 210	0:45 - 1:15
Duck	1.5 - 2 kg	Turbo Grill	1	180 - 200	1:15 - 1:45
Goose	3.5 - 5 kg	Turbo Grill	1	160 - 180	2:30 - 3:30
Turkey	2.5 - 3.5 kg	Turbo Grill	1	160 - 180	1:45 - 2:30
Turkey	4 - 6 kg	Turbo Grill	1	140 - 160	2:30 - 4:00

Main Oven - Full Width Grilling

 Adjust shelf position and grill pan grid to suit different thicknesses of food

Food	Grill Time (mins in total)
Bacon Rashers	5- 6
Beefburgers	10 - 20

Food	Grill Time (mins in total)
Chicken Joints	20 - 40
Chops	
- Lamb	15 - 25
- Pork	20 - 25
Fish - Whole Trout/ Makarel	10 - 12
Fillets - Plaice/Cod	4 - 6
Kebabs	12 - 18
Kidneys - Lamb/Pig	6 - 10
Sausages	20 - 30
Steaks	
- Rare	4 - 6
- Medium	6 - 8
- Well Done	12 - 15
Toasted Sandwiches	3 - 4

Main Oven - Fan Cooking



Shelf Positions are not critical but ensure that oven shelves are evenly spaced when more than one is used (e.g. shelf positions 1 and 3)

Food	Temperature [°C]	Approx Cook Time (mins)
Biscuits	180 - 190	10 - 20
Bread	190 - 210	30 - 35
Cakes:		
- Small & Queen	160 - 170	18 - 25
- Sponges	160 - 170	20 - 25
- Madeira	140 - 160	60 - 75
- Rich Fruit	130 - 140	120 - 150
- Christmas	130 - 140	180 - 270
Fish	160 - 180	20 - 30

Food	Temperature [°C]	Approx Cook Time (mins)
Fruit Pies, Crumbles	170 - 180	30 - 50
Milk Puddings	140 - 160	60 - 90
Pastry:		
- Choux	180 - 190	30 - 40
- Shortcrust	180 - 190	25 - 35
- Flaky	180 - 190	30 - 40
- Puff	Follow manufacturer's instructions; Reduce the temperature for Fan oven by 20°C	
Plate Tarts	180 - 190	25 - 45
Quiches/Flans	170 - 180	25 - 45
Scones	210 - 230	8 - 12
Roasting: Meat and Poultry	160 - 180	see Roasting Chart

Main Oven - Fan Cooking

Meat	Temperature [°C]	Cooking Time
Beef/ Beef boned	160 - 180	20-35 minutes per ½ kg (1lb) and 20-35 minutes over
Mutton/ Lamb	160 - 180	20-35 minutes per ½ kg (1lb) and 20-35 minutes over
Pork/ Veal/ Ham	160 - 180	30-40 minutes per ½ kg (1lb) and 30-40 minutes over
Chicken	160 - 180	15-20 minutes per ½ kg (1lb) and 20 minutes over
Turkey/ Goose	160 - 180	15-20 minutes per ½ kg (1lb) and 20 minutes over
Duck	160 - 180	25-35 minutes per ½ kg (1lb) and 25-30 minutes over
Pheasant	160 - 180	35-40 minutes per ½ kg (1lb) and 35-40 minutes over
Rabbit	160 - 180	20 minutes per ½ kg (1lb) and 20 minutes over

Main Oven - Conventional Cooking

Food	Shelf Position	Temperature [°C]	Approx Cook Time (mins)
Biscuits	3	180 - 190	10 - 20
Bread	3	200- 220	30 - 35
Cakes:			
- Small & Queen	3	170 - 180	18 - 25
- Sponges	3	170 - 180	20 - 25
- Madeira	3	150 - 160	60 - 75
- Rich Fruit	2	140 - 150	120 - 150
- Christmas	2	140 - 150	180 - 270
Fish	3	170 - 180	20 - 30
Fruit Pies, Crumbles	3	180 - 200	30 - 50
Milk Puddings	3	150 - 170	60 - 90
Pastry:			
- Choux	3	180 - 190	30 - 40
- Shortcrust	3	190 - 200	25 - 35
- Flaky	3	190 - 210	30 - 40
- Puff	Follow manufacturer's instructions		
Plate Tarts	3	190 - 200	25 - 45
Quiches/Flans	3	200 - 210	25 - 45
Scones	3	220 - 230	8 - 12
Roasting: Meat and Poultry	3	170 - 190	see Roasting Chart

Care and cleaning



Warning! When cleaning, the appliance must be switched off and cooled down.



Warning! Cleaning the appliance with a steam jet or high-pressure cleaner is prohibited for safety reasons.



Caution! Do not use scourers, sharp tools or rinsing devices to clean the appliance.

Do not use scourers or metal scrapers to clean the glass oven door, as these could scratch the surface. This could cause the glass to shatter.

The outside of the appliance

- Wipe the front of the appliance with a soft cloth and a solution of warm water and washing-up liquid.
- For metal surfaces use standard commercial cleaning products.
- Please do not use any scouring agents or abrasive sponges.

Clean the oven after every use. This is the easiest way to remove dirt which then cannot burn on.

Inside of the oven

1. When the oven door is opened, the oven light bulb automatically illuminates.
2. Wipe out the oven after every use with a solution of washing-up liquid and then dry it.



Remove stubborn dirt with special oven cleaners.

Important! When using oven sprays, please follow the manufacturer's instructions exactly. Make sure that no visible remaining detergents are left after the cleaning with oven spray!

Accessories

- Clean and dry the oven accessories (shelf, tray, roasting pan, etc.) after each use. Soak the items to make cleaning easier.

Catalytic cavity cleaning (selected models only)



Warning! You must not wipe out the cavity side walls. It will damage the catalytic surface.

1. Remove all slide-in parts from the oven.
2. Wipe the floor of the oven clean with warm washing-up solution and dry.
3. Set the oven CATA function. You will find it in menu after other oven functions.
4. Oven will switch off after one hour.
5. Wipe away any remaining damp from the floor with soft sponge.



Warning! Before you wipe away wait until the cavity is cool.



Warning!

Do not use oven spray or abrasive cleaning agents. Do not use soap or other cleansing agents. The catalytic coating may otherwise be damaged.



After long periods of use, the catalytic coating may become slightly discoloured. This has no effect on the catalytic properties.

Side rails

The side rails on the right and left-hand side of the oven interior can be removed for the purpose of cleaning the side walls.

Removing the side rails

First pull the rails away from the oven wall at the front (1) and then unhook them at the back (2).

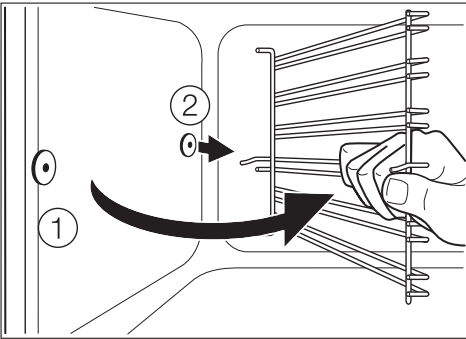
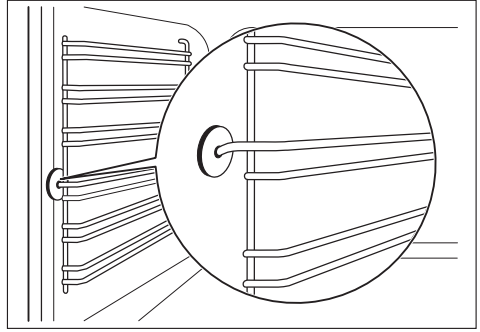
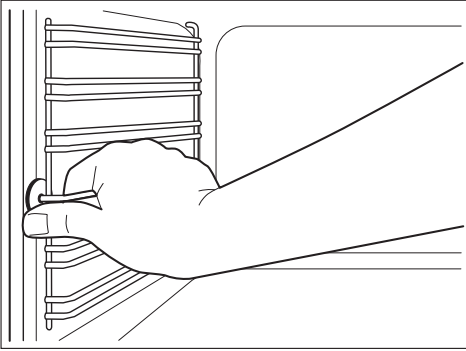

Replace the side rails

Important! Important The rounded ends of the guide bars must point to the front.

To install, first insert the rails in the holes at the back (1) and then lower into position at the front and press into place (2).

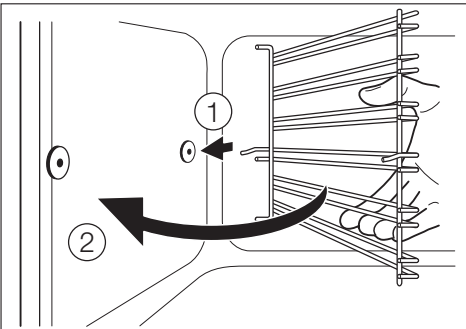

Oven back lamp (for selected models only)



Warning! Risk of electric shock!
Before replacing the oven light bulb:

- Switch oven off.
- Unscrew the fuse from the fuse box or switch fuse off.



To protect the oven light bulb and the glass cover, lay a cloth on the floor of the oven.

Replacing the oven light bulb/ Cleaning the glass cover

1. Take off the glass cover by turning it anticlockwise and clean it.

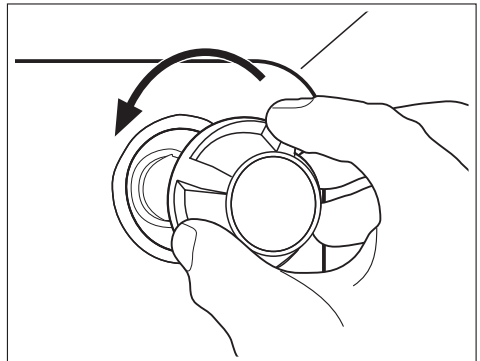

2. If necessary:

replace with a **40 Watt, 230V, 300°C heat-resistant oven light bulb** .

3. Refit the glass cover.

Replacing the side oven lamp/Cleaning the glass cover (for selected models only)

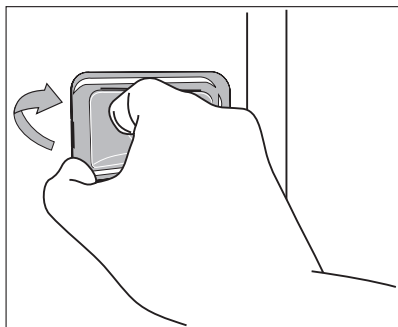

1. Take out the left-hand side rails.
2. Remove the glass cover with the help of a small, blunt object (e.g. a teaspoon) and clean it.
3. If necessary: replace halogen oven light bulb.
Order the replacement light bulb from the Customer Care Department (see section "Service/Customer Care Department").

i Always touch the halogen light bulb using a cloth to avoid grease contamination.

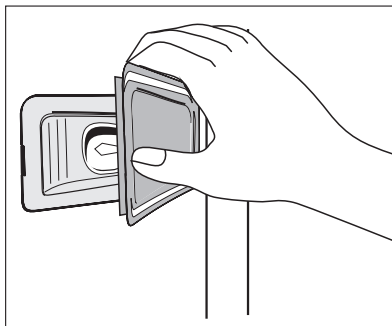

4. Refit the glass cover.
5. Replace the side rails.

Oven door glass

The oven door comprises four panels of glass mounted one on top of another. The interior glass panels can be removed for cleaning.

Important! Important: Rough handling, especially around the edges of the front panel, can cause the glass to break.

Removing the glass door panels

1. Open the door as far as it will go.

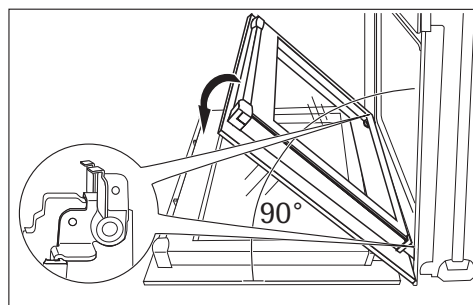

2. Loosen the **clamp levers** on both door hinges (A) **completely** .

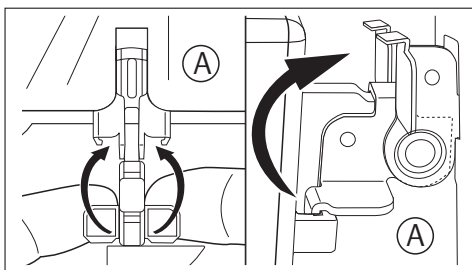

3. Close the oven door to the first open position (approx. 45°).

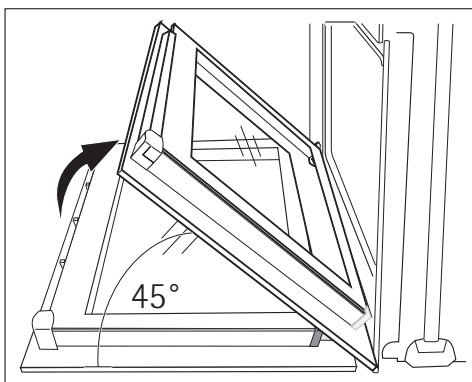

4. Hold the door strip (B) on the upper side of the oven door on both sides and press this inwards in order to loosen the seal. Then pull the door strip upwards and off.

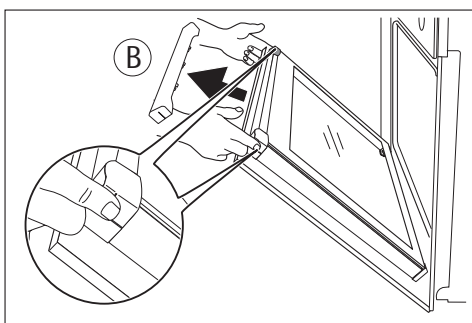

5. Hold the glass panels on their upper side and one after the other pull them up and out of their retainers.

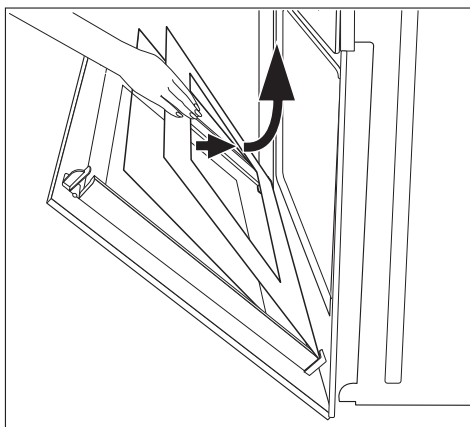

Cleaning the glass door panels

Thoroughly clean the glass door panels using a solution of water and washing-up liquid. Then dry them carefully.

Replacing the glass door panels

1. Slide the glass door panels one after the other into the retainers from above at an angle and then lower the panels.

i The two smaller panels should be inserted first, then the larger panel.

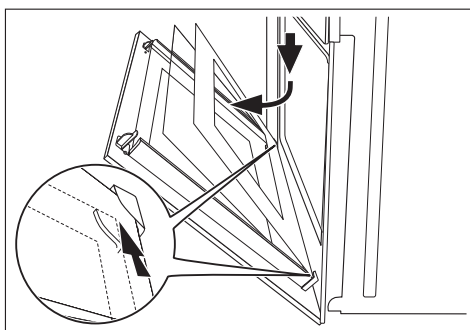

2. Hold the door strip (B) on both sides, align it with the inner edge of the door and press the door strip (B) into the upper edge of the door.

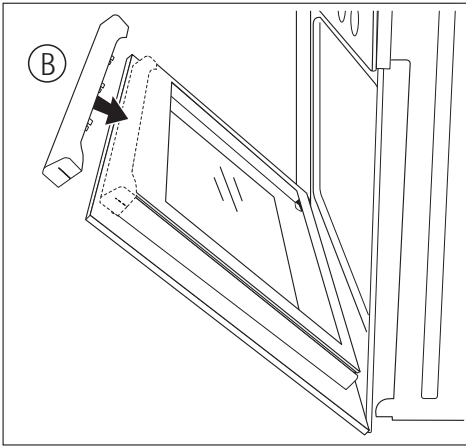

i On the open side of the door strip (B) there is a guide bar (C). This must be pressed between the outer side of the door and the corner (D). The seal (E) must audibly click into place.

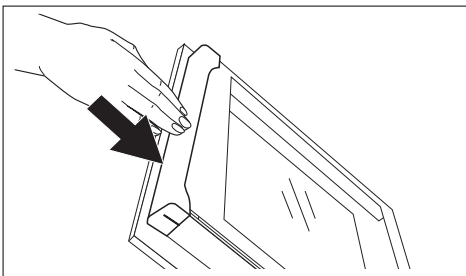
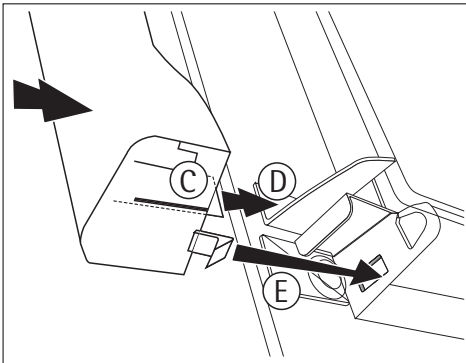

3. Open the door as far as it will go.

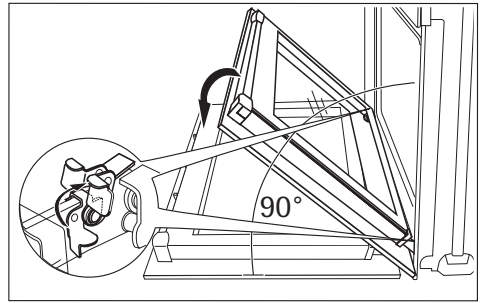

4. Fold the clamp levers on both door hinges (A) down into their original position.

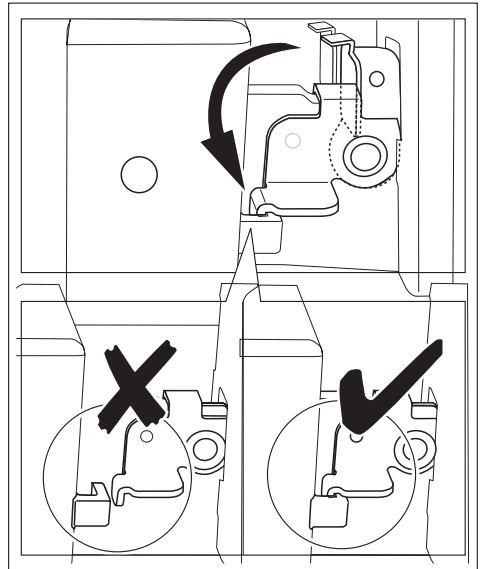

5. Close the oven door.

! **Warning!** Before cleaning always allow the appliance to cool down before switching off at the electricity supply.

Cleaning materials

Before using any cleaning materials on your appliance, check that they are suitable and that their use is recommended by the manufacturer.

Cleaners that contain bleach should not be used as they may dull the surface finishes. Harsh abrasives and scourers should also be avoided.

Cleaning the outside of the appliance

Do not use abrasive cleaning materials e.g. abrasive cream cleaners, wire wool pads or scourers on painted or printed finishes as damage may occur. Regularly wipe over the control panel, control knobs, handles, doors and appliance sides using a soft cloth and hot soapy water. To prevent streaking, finish with a soft cloth.

Stainless Steel cream cleaners are abrasive and should be avoided as they may dull the surface finish. **Any spillage on the stainless steel finish must be wiped off immediately.**



Warning! Do not attempt to remove any of the control knobs from the appliance as this may cause damage and is a safety hazard.

Cleaning inside the grill and oven compartments

The vitreous enamel coating in the grill/top oven and main oven compartments can be cleaned using normal oven cleaners with care. Ensure that the manufacturers instructions are followed and that all parts are well rinsed afterwards.



Warning! Aerosol cleaners must not come into contact with elements, the door seal, or any painted finishes as this may cause damage.

Cleaning the door(s)



Warning! Under no circumstances should the door assembly be detached from the product for cleaning.



Warning! To prevent damaging or weakening the door glass panels avoid the use of the following:

- Household detergents and bleaches.
- Soap Impregnated pads unsuitable for non-stick saucepans.
- Abrasive cleaning pads, scorers and steel wool pads.
- Chemical oven pads or aerosols.
- Rust removers.
- Bath/Sink stain removers.

Cleaning between the outer and inner door glass

The door glass is removable for cleaning. Clean the outer and inner glass using hot soapy water or hob cleaner may be used. Do not use hob cleaner on the Stainless Steel or painted finishes.

Ensure that all parts are well rinsed and thoroughly dried before attempting to replace the outer door.

What to do if...



Warning! Repairs to the appliance must only be carried out by qualified service engineers. Considerable danger to the user may result from improper repairs.



In the case of misuse the visit by the Customer Care Department technician or the repair may be chargeable, even during the warranty period.



Information for appliances with metal fronts:

Due to the appliance's cool front, when the door is opened during or shortly after baking or roasting, there may be condensation of the inner glass panel for a short while.

Please carry out the following checks on your appliance before calling a Service Engineer. It may be that the problem is a simple one which you can solve yourself without the expense of a service call.

In-guarantee customers should make sure that the checks have been made as the engineer will make a charge if the fault is not a mechanical or electrical breakdown.

Please note that proof of purchase is required for in-guarantee service calls.

Problem	Possible Solution
The grill, ovens and timer do not work.	Check that the appliance has been wired in to the appliance supply and is switched on at the wall.
	Check that the main appliance fuse is working.
	If you have checked the above: Allow the appliance to cool for a couple of hours. The appliance should now be working normally.
The grill does not work or cuts out after being used for a long period of time.	Ensure the cooling fan is running when the grill is on. If the cooling fan fails, the grill will not operate correctly. Contact your local service force centre.
	Leave the grill door open and allow the grill to cool. After a couple of hours check that the grill works as normal
The indicator neons are not working correctly.	Check that you have selected only the function you require. Ensure all other controls are in the off position.
The oven is not cooking evenly.	Check that the appliance is correctly installed and is level.
	Check that the recommended temperatures and shelf positions are being used.
The oven light fails to illuminate.	The oven light bulb may need replacing.

Problem	Possible Solution
The oven fan is noisy.	Check that the oven is level.
	Check that the shelves and bakeware are not vibrating in contact with the oven back panel.
The oven temperature is too high or too low.	Check that the recommended temperatures and shelf positions are being used. Be prepared to adjust the temperature up or down slightly to achieve the results you want.

Installation

- The set-up of the electrical installation is arranged so that the appliance can be isolated from the mains with a minimum 3 mm all-pole contact separation. Suitable isolation devices include, for example, circuit breakers, fuses (screw type fuses are to be removed from the holder), RCDs and contactors.
- Anti-shock protection must be provided by the installation.
- The built-in unit must meet the stability requirements of DIN 68930.
- Built-in cookers and cooking surfaces are equipped with special attachment systems. For safety reasons, they must only be

combined with appliances from the same manufacturer.

The use of heat protection strips is prohibited for cookers and ovens with Pyrolytic Cleaning, if the recess has a rear wall and closed ground-level compartment. However installation is possible with a ground-level compartment that has been shortened by at least 20 mm and which has base ventilation of the same cross-section.

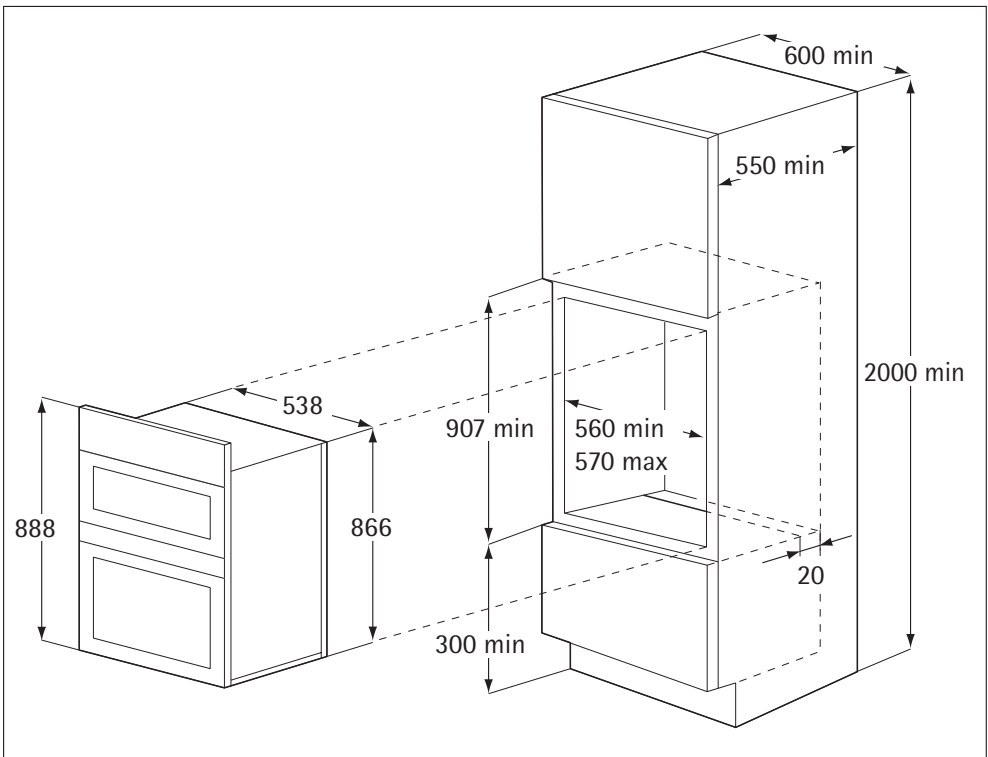

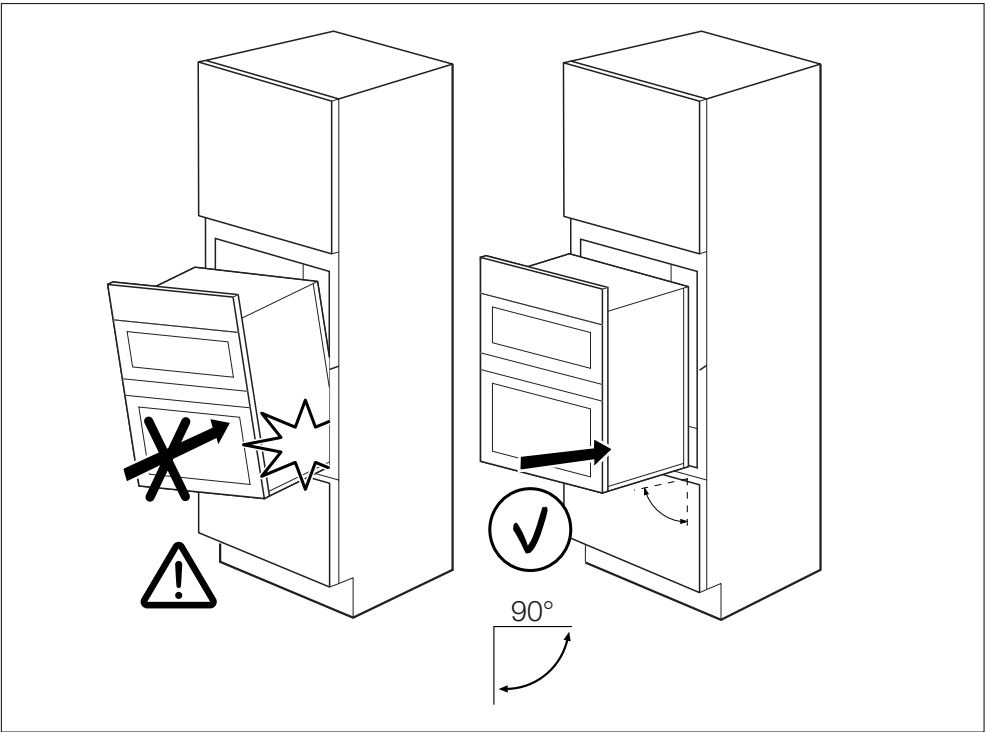
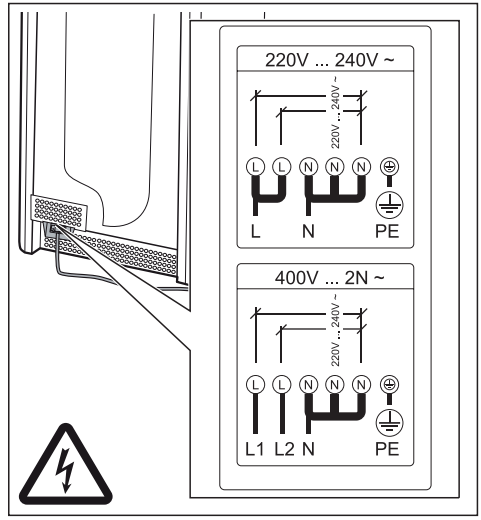
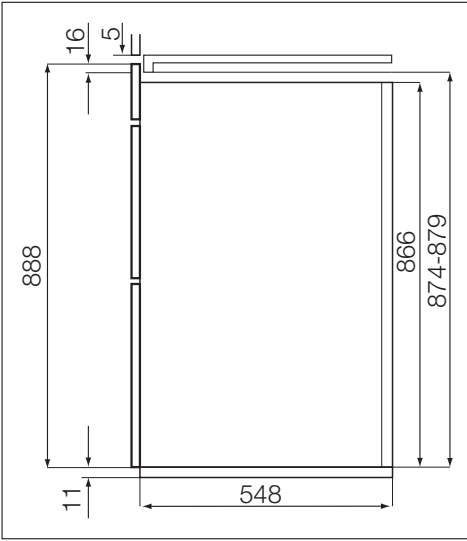

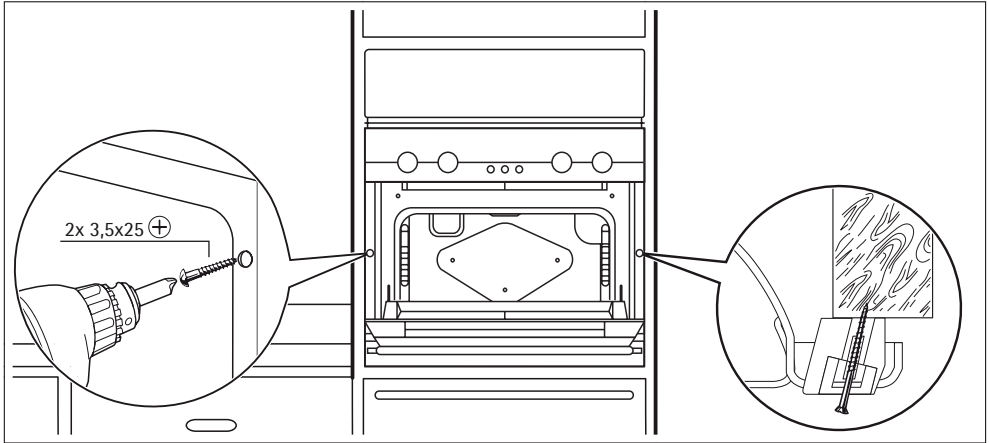

Electrical Installation

- Enquiries regarding the installation of the cooker point, if required, should be made to your Regional Electricity Company to ensure compliance with their regulations.
- The appliance socket switch should be outside the cabinet but within 2m of the appliance to make it accessible to switch off the appliance in case of an emergency.
- To protect the hands, wear gloves when lifting the oven into its housing.

Important! HOUSE CIRCUIT

Earth leakage and continuity tests must be carried out before the appliance is connected to the mains supply and re-checked after fitting.

GETTING THINGS READY CHOICE OF ELECTRICAL CONNECTION

There are three possible ways to connect your appliance. In each case the appliance should be operated using at least 6mm² twin core and earth PVC insulated multicore cable. Please choose from the most appropriate after reading the different methods :

- a) By connecting to a cooker point (having a double pole isolating switch with at least 3mm contact separation in all poles and neutral) and protected with a fuse or miniature circuit breaker at your mains fuse box.
- b) By connecting the appliance together with a hob directly to a cooker point(s). Having a double pole isolating switch with at least 3mm contact separation in all poles and neutral.
- c) If you wish to connect an oven and a hob to a cooker point you can by connecting the oven and hob separately to the cooker point. Oven and hob units should be separately connected to a cooker point. (See Picture)

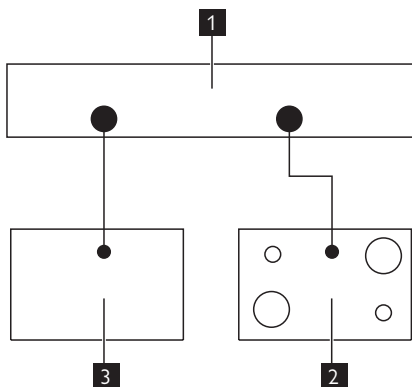

- 1** Cooker Point
- 2** Hob
- 3** Oven

It is good practice to :

- Fit an Earth Leakage Circuit Breaker to your house wiring.
- Wire your appliance to the latest IEE regulations.

Disposal

The symbol  on the product or on its packaging indicates that this product may not be treated as household waste. Instead it should be taken to the appropriate collection point for the recycling of electrical and electronic equipment. By ensuring this product is disposed of correctly, you will help prevent potential negative consequences for the environment and human health, which could otherwise be caused by inappropriate waste handling of this product. For more detailed information about recycling of this product, please contact your local council, your household waste disposal service or the shop where you purchased the product.



Warning! Your appliance should be made inoperable before it is disposed of, so that it does not constitute a danger.

To do this, take the mains plug from the socket and remove the mains cable from the appliance.



Packaging material

The packaging material is environmentally-friendly and recyclable. Plastic parts are marked with the international abbreviations such as, e.g. >PE<, >PS< etc. Dispose of the packaging material in the containers provided for this purpose at your local waste management facility.

Repairs - after sales service

Your appliance comes with a three year warranty. If it is not working correctly; consult the fault finding guides within this instruction book (Something not working). If a fault occurs which you can not resolve through following the advice and information contained within this instruction manual, the next step is to contact our extended warranty administrators on:

0844 871 7771

They will give you details for your local Service engineer. Before calling out an engineer, please ensure you have read the details under the heading "Something not working".

When you contact your local service engineer you will need to give the following details:

1. Your name, address and post code
2. Your telephone number
3. Clear and concise details of fault
4. The purchase date as found on your receipt
5. The model and serial number of the appliance. So that you always have these numbers at hand, we recommend you to make a note of them here:

- Mod.....
- P.N.C.....
- S.N.....

IMPORTANT : If you call out an engineer to a fault listed below, or to repair a fault caused by incorrect use or installation, a charge will be made even if the appliance is under guarantee.

Spare parts

This oven should be serviced by any authorised service engineer; and only genuine spare parts should be used.

Under no circumstances should you attempt to repair the oven yourself.

Repairs carried out by inexperienced persons may cause injury or serious malfunctioning.

Contact our extended warranty administrators on

0870 010 7887

who will give you details for your Service Force repair agent.

Always insist on genuine spare parts.

www.electrolux.com

Albania	+35 5 4 261 450	Rr. Pjeter Bogdani Nr. 7 Tirane

Belgique/België/Belgien	+32 2 363 04 44	Bergensesteenweg 719, 1502 Lembeek
Česká republika	+420 261302111	Budčjovická 3, Praha 4, 140 21
Danmark	+45 70 11 74 00	Sjællandsgade 2, 7000 Fredericia
Deutschland	+49 180 32 26 622	Fürther Str. 246, 90429 Nürnberg
Eesti	+37 2 66 50 030	Pärnu mnt. 153, 11624 Tallinn
España	+34 902 11 63 88	Carretera M-300, Km. 29,900 Alcalá de Henares Madrid
France	08 44 62 26 53	www.electrolux.fr
Great Britain	+44 8445 616 616	Addington Way, Luton, Bedfordshire LU4 9QQ
Hellas	+30 23 10 56 19 70	4, Limnou Str., 54627 Thessaloniki
Hrvatska	+385 1 63 23 338	Slavonska avenija 3, 10000 Zagreb
Ireland	+353 1 40 90 753	Long Mile Road Dublin 12
Italia	+39 (0) 434 558500	C.so Lino Zanussi, 26 - 33080 Porcia (PN)
Latvija	+371 67313626	Kr. Barona iela 130/2, LV-1012, Riga
Lietuva	+370 5 278 06 03	Ozo 10a, LT-08200 Vilnius
Luxembourg	+352 42 431 301	Rue de Bitbourg, 7, L-1273 Hamm
Magyarország	+36 1 252 1773	H-1142 Budapest XIV, Erzsébet királyné útja 87
Nederland	+31 17 24 68 300	Vennootsweg 1, 2404 CG - Alphen aan den Rijn
Norge	+47 81 5 30 222	Risløkkvn. 2 , 0508 Oslo
Österreich	+43 18 66 400	Herziggasse 9, 1230 Wien
Polska	+48 22 43 47 300	ul. Kolejowa 5/7, Warszawa
Portugal	+35 12 14 40 39 39	Quinta da Fonte - Edificio Gonçalves Zarco - Q 35 -2774-518 Paço de Arcos
Romania	+40 21 451 20 30	Str. Garii Progresului 2, S4, 040671 RO

Schweiz - Suisse - Svizzera	+41 62 88 99 111	Industriestrasse 10, CH-5506 Mägenwil
Slovenija	+38 61 24 25 731	Gerbičeva ulica 98, 1000 Ljubljana
Slovensko	+421 (02) 32141334	Electrolux Slovakia s.r.o., Electrolux Domáce spotrebičle SK, Seberíniho 1, 821 03 Bratislava
Suomi	www.electrolux.fi	
Sverige	+46 (0)771 76 76 76	Electrolux Service, S:t Göransgatan 143, S-105 45 Stockholm
Türkiye	+90 21 22 93 10 25	Tarlabası caddesi no : 35 Taksim İstanbul
Россия	+7 495 937 7837	129090 Москва, Олимпийский проспект, 16, БЦ "Олимпик"
Україна	+380 44 586 20 60	04074 Київ, вул.Автозаводська, 2а, БЦ "Алкон"

John Lewis Partnership

171 Victoria Street
London SW1E 5NN
www.johnlewis.com